

## FAA-Approved 4-PLACE PANEL MOUNT INTERCOM

The PM1000II is a 4-place panel mounted intercom (expandable to up to 8 places) with individual volume and squelch controls for both the pilot and copilot.

A multi-position mode switch allows the pilot to select up to three configurations depending on the PM1000II part number.

The ISO mode isolates the pilot from the intercom, and connects directly with the aircraft radios. The copilot and passengers are free to have conversation and enjoy the entertainment without radio interruption. The pilot is not distracted by passenger intercom use and has control over the radio communications.

The "ALL" mode places everybody on a party line. Each person hears all intercom conversation and aircraft radio reception. Everyone hears the entertainment source as well.

Some models of the PM1000II (see ordering information) include an optional "CREW" mode. In CREW mode, the pilot and copilot are on one intercom channel, while the passengers have conversation on another. In this mode, two independent music inputs are active. The pilot and copilot listen to Beethoven, as the passengers listen to Rock and Roll.

Benefiting from 14 years of excellence in VOX circuit design, the PM1000II takes ultimate advantage of independent microphone circuits to keep unwanted noise out of the audio. Since only the microphone being spoken into is open, extraneous cabin noise is minimized. Individual squelch controls mean that the system can be tailored to different microphones, as well as variations in voice levels in the cockpit.

The PM1000II provides entertainment input. When the intercom or aircraft becomes active, the music will automatically mute, allowing communications without distraction. When the activity ceases, the SoftMute(tm) circuit gradually returns the music to the original volume. A slight delay prevents lost syllables and choppy conversation.

The PM1000II has an automatic fail-safe interconnect to the aircraft systems. If power to the intercom is disrupted, the pilot's headset is automatically connected to the aircraft radio. This permits continuous radio communications.

Because the pilot and copilot volume control does not affect the aircraft radio volume, balance between the intercom and radio audio is easily achieved. For instance, by reducing the pilot's intercom volume, the aircraft radio volume will be in the foreground, while the intercom will be at a background level.

With the PM1000II installed, both pilot and copilot have transmit capability over the

aircraft radio. Only the person who presses the PTT is heard over the radio. A 2-color LED shows green when power is on, and red during radio transmissions. This feature acts as a stuck microphone indication.

An optional internal digital recorder (p/n 11906 or 11908, non-TSO) can provide up to one minute of stored aircraft radio reception. This device is a continuous loop recorder that

automatically starts recording the instant a radio transmission is received, with no dead air time recorded. By pressing a momentary switch, the last recorded messages will be replayed. Up to 16 messages (or 1 minute) can be stored.

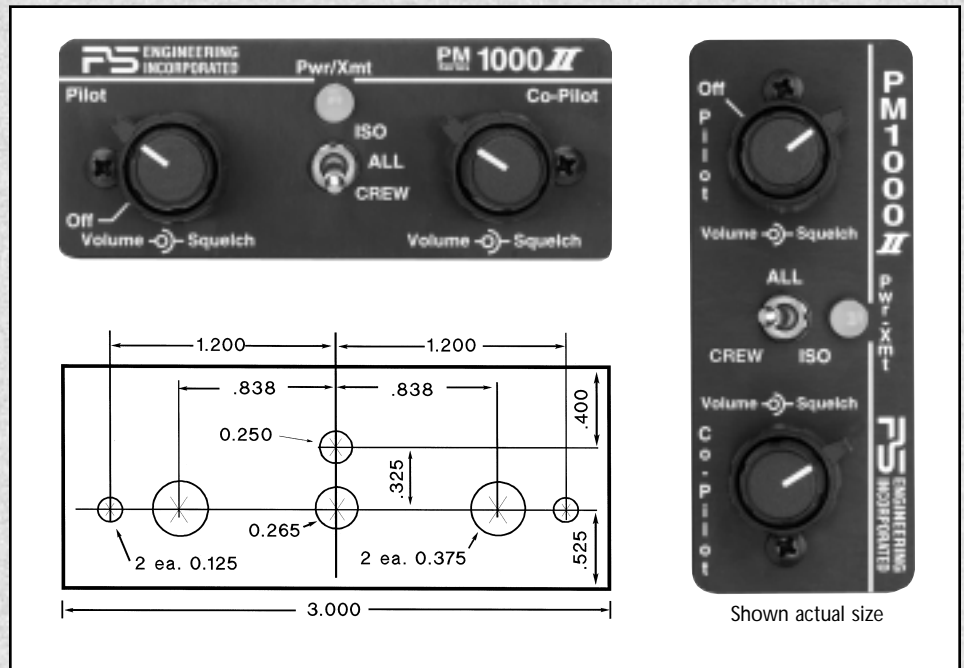

### ORDERING INFORMATION

**PM1000II 4-Place Intercom, FAA-TSO** .....11922  
 4-place panel mount intercom with Isolate and all modes, single music input. Installation hardware includes four sets of headset jacks, a music jack and reversible (horizontal and vertical) metal mounting plate.  
**Same as above with 1-minute digital recorder (non-TSO)** .....11906

**PM1000II 4-Place Intercom with Crew, FAA-TSO** .....11920  
 4-place panel mount intercom with Isolate, Crew and all modes, dual music input. Installation hardware includes six sets of headset jacks, two music jacks and reversible (horizontal and vertical) metal mounting plate.  
**Same as above with 1-minute digital recorder (non-TSO)** .....11908

**Narrow Mic Bandwidth** .....NBW  
 Modify any PM1000II for extreme noise conditions (non-TSO)

**PM1200 2-Place Intercom PTT ICS (non-TSO)** .....11960  
 2-place panel mount intercom with Isolate mode for installation in very high noise environments, such as open cockpits. Features AMP Active microphone filtering. Installation hardware includes headset jacks, music jacks and metal mounting plate.

**IntelliPAX 6-Place Expansion Unit** .....11616  
 Self-contained 6-place panel mount passenger expansion unit provides Crew mode, stereo music input with switchable SoftMute and input for public address messages. It has an automatic squelch control that adjusts the vox circuits and volume control that adjusts all headsets.  
**Same as above for blind mount** .....11616R

**2 1/4-inch round mounting plate** .....11911  
 Allows installation in a standard 2-inch instrument hole.  
**Same as above with Crew** .....11911C

# SPECIFICATIONS

**Input Power:** 12 - 28 Volts DC Current Drain: < 250 mA  
**Headphone Impedance:** 150 - 1000 Ohms typical  
**Audio Distortion:** <10% @ 70mW into 150 Ohm load  
**Aircraft Radio Impedance:** 1000 Ohms typical  
**3 dB Mic Frequency Response:** 350 Hz - 6000 Hz  
**3 dB Music Frequency Response:** 200 Hz - 15,000 Hz  
**Net weight:** 12 Ounces  
**Dimensions:** 1.25" H X 3.00" W X 5.50" D  
**FAA-TSO C50c:** RTCA/DO-170, DO160B,  
 A1CASXXXXXXXXBBBBBBX

**Optional Configurations:**

- Remotely locate the Volume and Squelch controls for the Copilot, great for Tandem Seating Aircraft.
- Custom Wire Harnesses made to your specifications
- Modify the microphone frequency response for noisier aircraft.
- Helicopter faceplate for proper intercom control orientation

**Warranty**

One year hassle-free Pro-Support warranty program, when installed by authorized PS Engineering dealer.  
 Out of warranty fixed repair fee is \$29.95.  
 See Warranty Information in the Installation Manual for details on our limited warranty or visit [www.ps-engineering.com](http://www.ps-engineering.com).

## PM1000II with Built-In Crew Function (11920) Wiring Diagram

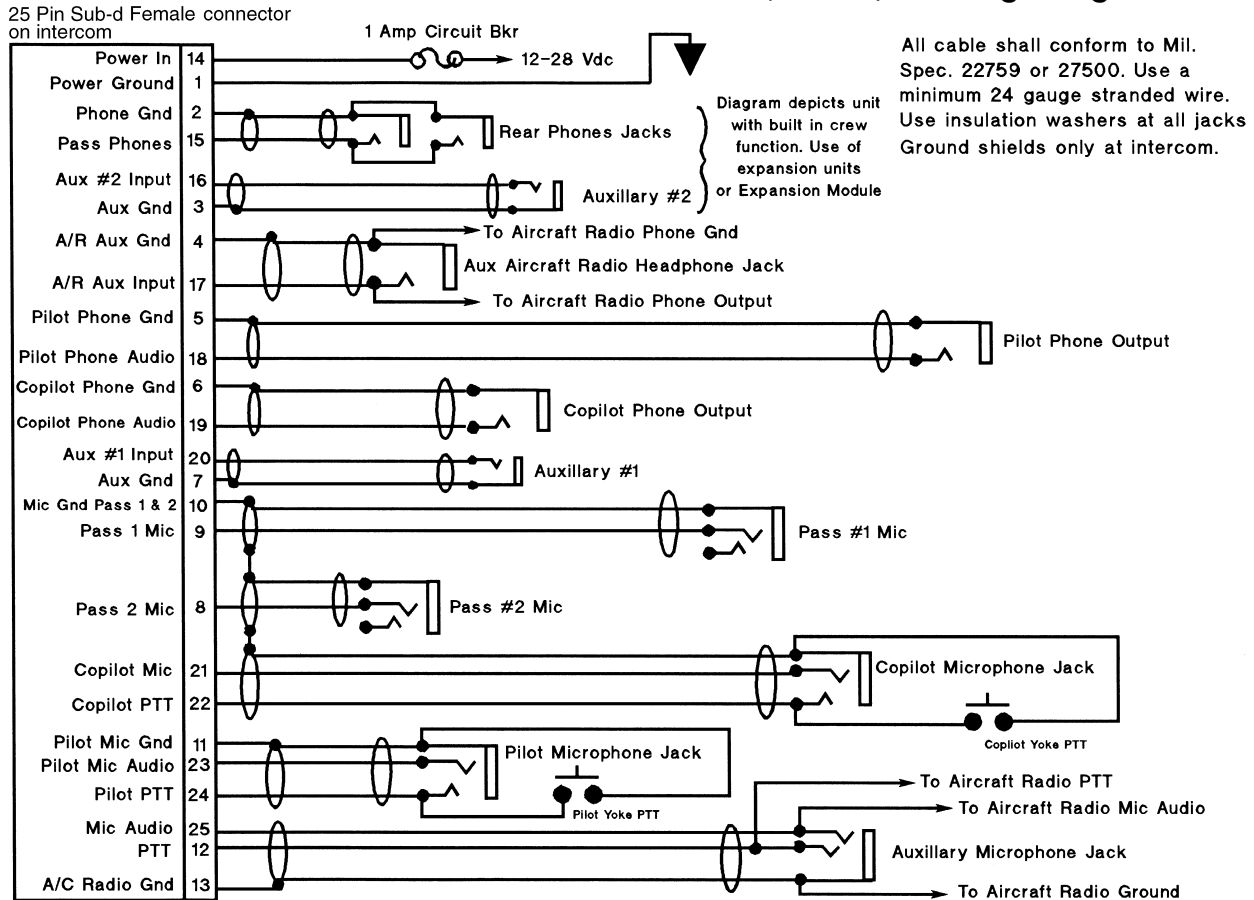

Mode	Pilot Hears	Copilot Hears	Passenger Hears	Comments
Isolate	A/C Radio Pilot sidetone (only during radio xmt.)	Copilot Passengers Music #1	Passengers Copilot Music #1	This mode allows the pilot to communicate with the ground without the copilot or the passengers hearing the conversation. Copilot and passengers can continue to communicate with themselves and continue to listen to Music #1.
All	Pilot A/C Radio Copilot Passengers Music #1	Copilot A/C Radio Pilot Passengers Music #1	Passengers A/C Radio Pilot Copilot Music #1	This mode allows the pilot, copilot and passengers to communicate with each other. All will hear aircraft radio. Music is muted (lowered in level) during intercom or radio communications. Music and intercom are disabled during radio transmissions.
Crew	Pilot Copilot A/C Radio Music #1	Pilot Copilot A/C Radio Music #1	Passengers Music #2	While in the Crew mode, the pilot and copilot are on one channel while the passengers are on a separate channel. Additionally, the pilot and copilot will hear Music #1 while the passengers will hear music #2. Only the pilot and copilot will hear the aircraft radio.

PS Engineering, Inc. • 9800 Martel Road • Lenoir City, TN 37772

Phone (865) 988-9800 • FAX (865) 988-6619 • Internet [www.ps-engineering.com](http://www.ps-engineering.com)